

ELEPHANT

HEAVY DUTY ELECTRIC CHAIN BLOCK



DA type • DB type

SINGLE SPEED **DOUBLE SPEED**

No.2



QUALITY SYSTEM

JQA-1547



ELEPHANT CHAIN BLOCK CO.,LTD.

EPDFDA-2

ELEPHANT ELECTRIC CHAIN BLOCK DA/DB TYPE IS DESIGNED BY UNIQUE IDEA AND TRUSTABLE TECHNIQUE. THIS TYPE IS USEFUL FOR VARIOUS OPERATIONS OF HEAVY LOAD.

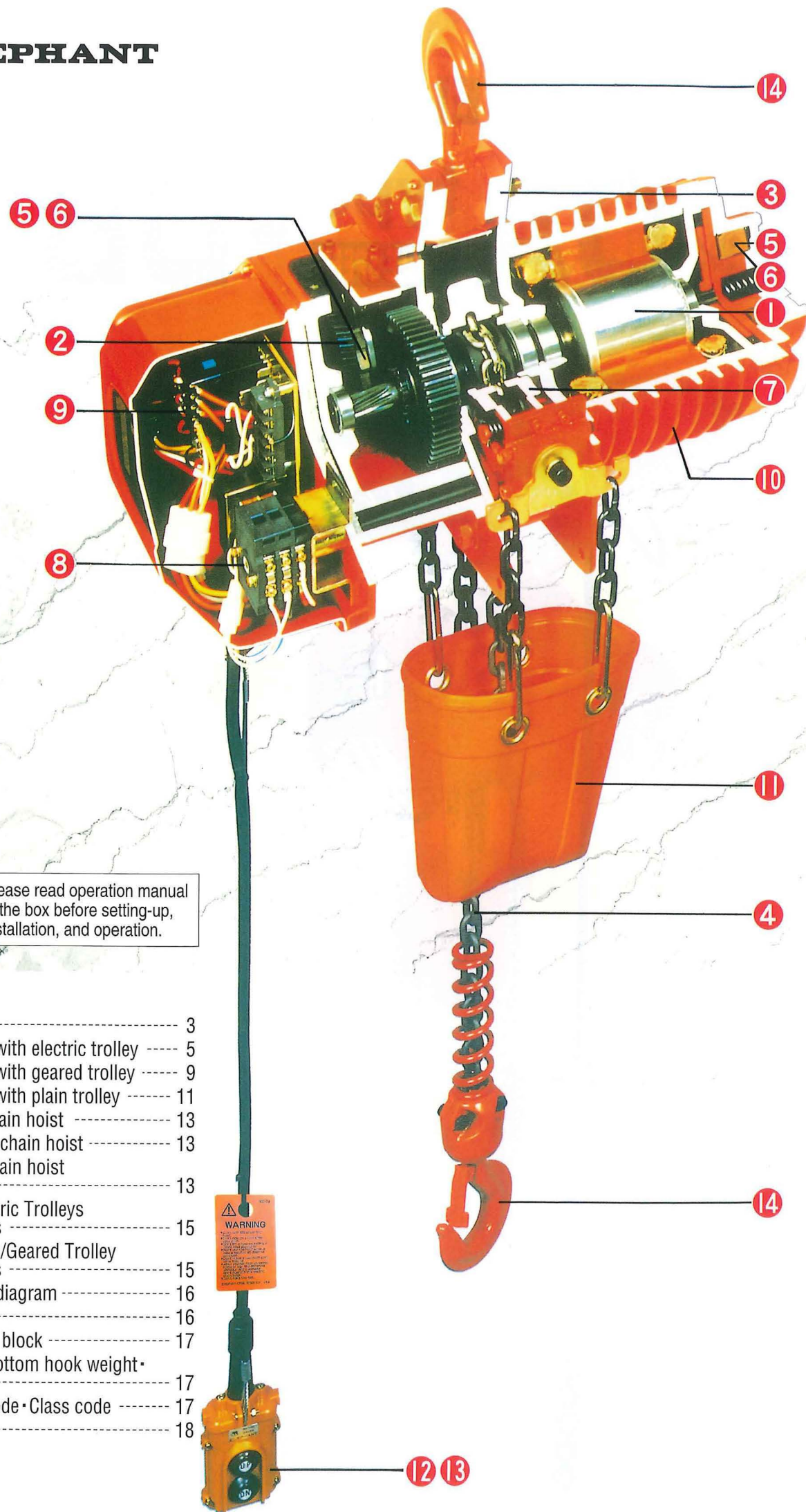

FEATURES OF DA/DB TYPE

- ① **High speed and highly efficient lifting motor**
To meet any severe conditions of operating the chain block, DA/DB model employs the newly-developed lifting motor which allows it to operate continuously for a long period and with the frequent starts/hour duties. Its lifting speed is made as high as possible to ensure the enhanced working efficiency.
- ② **Noiseless and dust protective body**
Durable helical gears & oil bath type gear case make quiet operation.
- ③ **Solid steel side plate**
- ④ **Highly durable load chain**
The load chain is the surface-hardened one whose properties completely agree with the ISO standard Grade T, offering the satisfactory degrees of breaking strength, wear resistance and impact absorption. Chains of high corrosion resistance for special uses are available upon request.
- ⑤ **Mechanical brake and motor brake—safe double brake**
The electric-magnetic brake is combined together with the mechanical brake to constitute a complete double brake system, and even the former alone has enough capacity to hold a static safe working load.
- ⑥ **DC brake and motor with low power consumption**
D.C. solenoid is used for the electro-magnetic brake, and this promises lower electrical consumption throughout the operation of the electric chain block.
- ⑦ **Unique chain guide**
Since this new chain block is designed in such a way that the chain guide rotation on the load sheave is transmitted to the electrical limit switch, operation stops automatically by the function of the limit switch, not only when the chain is wound up or down to its end, but also in situations like as the dust and foreign matters remain pressed and kept in the pockets of load sheave.
- ⑧ **Reliable double—action electrical limit switch**
Electrical limit switch for this model acts with two steps. At the first step, the limit switch breaks the operating circuit, and at the following step, it breaks the main power circuit.
- ⑨ **Negative phase contactor and highly efficient magnetic contactor with mechanical & electrical interlock**
- ⑩ **Motor frame**
Cooling fin of aluminum motor frame can reduce the rise of temperature.
- ⑪ **High durability Chain bucket**
- ⑫ **Control switch voltage set at 24V**
- ⑬ **Push-push type push button switch (DB type)**
- ⑭ **Top hook and bottom hook with safety latch**
While overload situation, hooks open gradually and not break suddenly. Further compact thrust bearing prevent twisting of load chain.

CAUTION Please read operation manual in the box before setting-up, installation, and operation.

Contents

Electric chain block	3
Electric chain block with electric trolley	5
Electric chain block with geared trolley	9
Electric chain block with plain trolley	11
Low head electric chain hoist	13
Synchronized electric chain hoist	13
Low head manual chain hoist with geared trolley	13
Combination of Electric Trolleys with Traversing Rails	15
Combination of Plain/Geared Trolley with Traversing Rails	15
Notes on the wiring diagram	16
Hoist classification	16
Large capacity chain block	17
Hook dimensions • Bottom hook weight • Load chain weight	17
Reading of Model/Code • Class code	17
Definition of words	18

ELECTRIC CHAIN BLOCK

HOOK SUSPENSION TYPE

2 push button type (DA)



2 push button type (DB)



2 push button type (DA·DB)

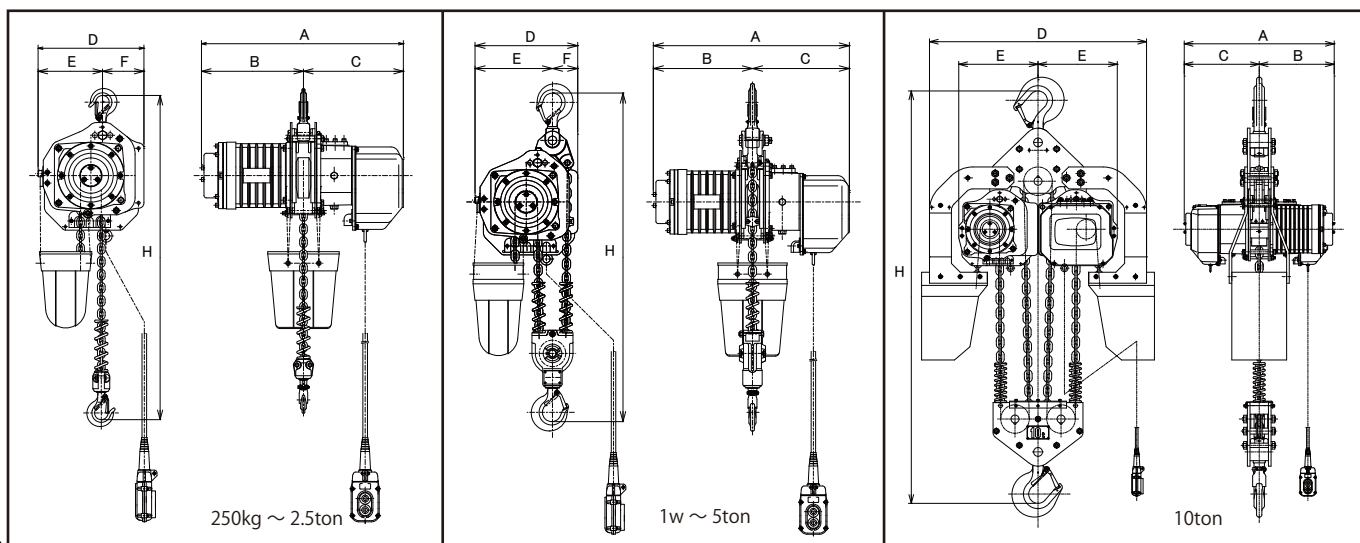
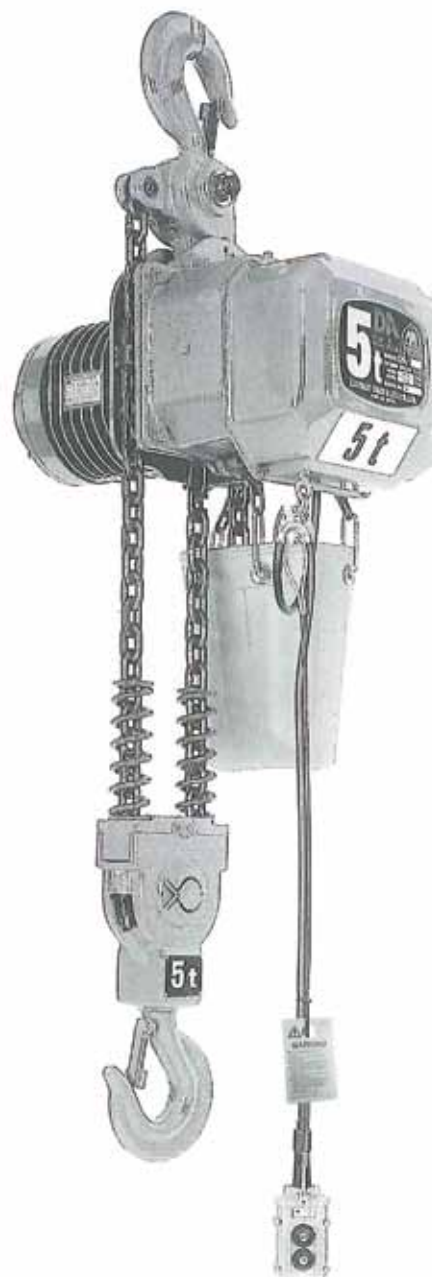

DA type(single speed)/DB type(double speed) SPECIFICATION

Model	Capacity (ton)	Test Load (ton)	Standard lift (m)	Standard push button cord length(m)	load chain dia x number of falls	Lifting motor output (kW) (DB)High:Low speed	Lifting speed(m/min) (DB)High:Low speed		Minimum distance H (mm)	Ampere (A) [220V]	Net weight (kg)
							50Hz	60Hz			
DA-0.25	250kg	313kg	3 or 6	2.5 or 5.5	5.6×1	0.5	7.8	9.3	525	2.5	51 (53)
DA-0.5	0.5	625kg			6.3×1	0.9	7.3	8.6	530	4.5	56 (59)
DA-1W	1	1.25			6.3×2	0.9	3.6	4.3	705	4.5	63 (69)
DA-1S	1	1.25			7.1×1	1.7	6.8	8.2	585	8.7	72 (76)
DA-1.5	1.5	1.88			9.5×1	3.4	8.7	10.3	730	15.3	120 (127)
DA-2W	2	2.5			7.1×2	1.7	3.4	4.1	790	8.7	84 (91)
DA-2S	2	2.5	11.2×1	3.4	6.9	8.1	730	15.3	124 (133)		
DA-2.5	2.5	3.13	4	3.5	11.2×1	3.4	5.5	6.5	730	15.3	128
DA-3	3	3.75			9.5×2	3.4	4.35	5.15	975	15.3	145
DA-5	5	6.25			11.2×2	3.4	2.75	3.25	1045	15.3	163
DA-10	10	12.5			11.2×4	3.4×2	2.7	3.2	1390	15.3	396
DB-0.25	250kg	313kg	3 or 6	2.5 or 5.5	5.6×1	0.5:0.17	7.8:2.6	9.3:3.1	525	2.6	56 (59)
DB-0.5	0.5	625kg			6.3×1	0.9:0.3	7.3:2.4	8.6:2.8	530	4.7	62 (66)
DB-1W	1	1.25			6.3×2	0.9:0.3	3.6:1.2	4.3:1.4	705	4.7	69 (76)
DB-1S	1	1.25			7.1×1	1.7:0.57	6.8:2.2	8.2:2.7	585	9.2	79 (84)
DB-1.5	1.5	1.88			9.5×1	3.4:1.14	8.7:2.9	10.3:3.4	730	16.0	136 (144)
DB-2W	2	2.5			7.1×2	1.7:0.57	3.4:1.1	4.1:1.3	790	9.2	92 (100)
DB-2S	2	2.5	11.2×1	3.4:1.14	6.9:2.3	8.1:2.7	730	16.0	141 (150)		
DB-2.5	2.5	3.13	4	3.5	11.2×1	3.4:1.14	5.5:1.8	6.5:2.1	730	16.0	144
DB-3	3	3.75			9.5×2	3.4:1.14	4.35:1.4	5.15:1.7	975	16.0	162
DB-5	5	6.25			11.2×2	3.4:1.14	2.75:0.9	3.25:1.0	1045	16.0	179

1) The number bracketed in "Net weight" indicates 6m lift. 2) The length of power cord is 4core-5m (standard).
3) Current ampere depends on the voltage and length of power cord.

DIMENSIONS

MODEL	A	B	C	D	E	F
DA-0.25/DB-0.25	528/563	267/276	261/287	276	168	108
DA-0.5/DB-0.5	528/590	267/303	261/287	276	168	108
DA-1W/DB-1W	528/590	267/303	261/287	276	208	68
DA-1S/DB-1S	564/619	290/321	274/298	301	174	127
DA-1.5/DB-1.5	655/717	342/372	313/345	372	198	174
DA-2W/DB-2W	564/619	290/321	274/298	301	219	82
DA-2S/DB-2S	655/717	342/372	313/345	372	198	174
DA-2.5/DB-2.5	655/717	342/372	313/345	372	198	174
DA-3/DB-3	655/717	342/372	313/345	372	258	114
DA-5/DB-5	655/717	342/372	313/345	375	273	102
DA-10	684	342	342	990	363	-

1) The dimensions D,E depends on the lift. 2) For top and bottom hooks, see page 17.

*The specification and dimensions may be changed without prior notice for improvement.

ELECTRIC CHAIN BLOCK WITH ELECTRIC TROLLEY

4 push button type (DA)
For monorail



6 push button type (DA)
For crane



Option: Wiring box for saddle

- Magnetic contactor and transformer are included.
- Operating voltage is 24V
- Power cord and operating cord are not included

4 push button type (DA)
For monorail



6 push button type (DA)
For crane



Option: Wiring box for saddle

- Magnetic contactor and transformer are included.
- Operating voltage is 24V
- Power cord and operating cord are not included

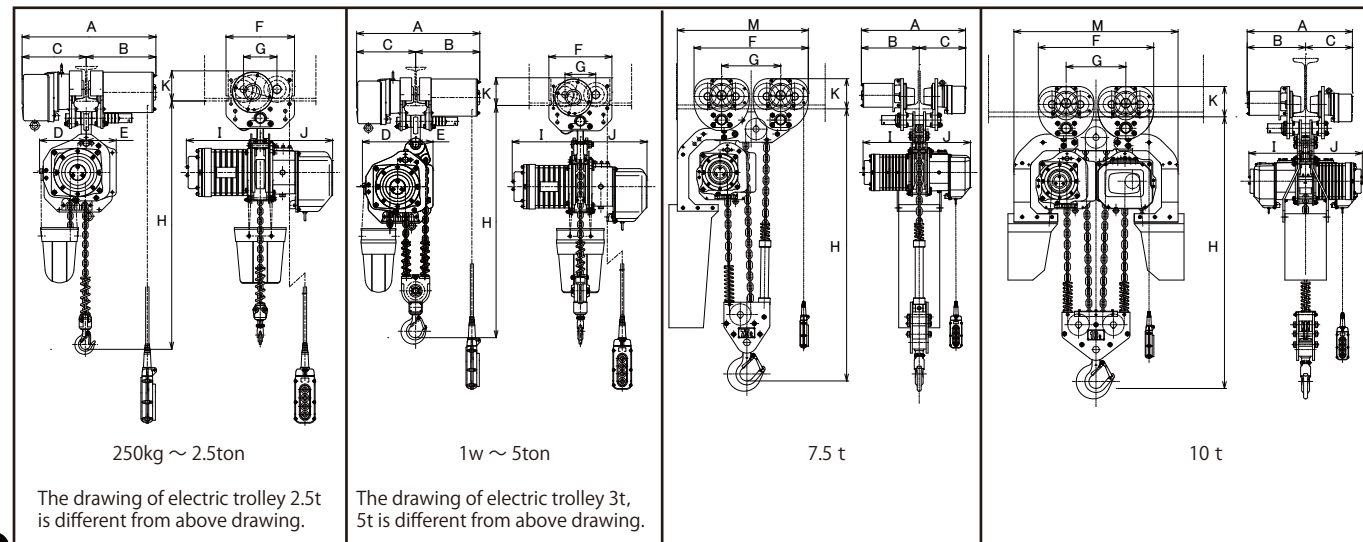

The drawing of electric trolley 2.5t is different from above drawing.

The drawing of electric trolley 3t, 5t is different from above drawing.

DAM type/DAMB type SPECIFICATION

Model	Capacity (ton)	Test Load (ton)	Standard lift (m)	Standard push button cord length (m)	Lifting motor output (kW)	Traversing motor output (MB) High:Low (kW)	Lifting speed (m/min)		Traversing speed (MB) High:Low (m/min)		Minimum distance H (mm)	Traversing I beam width	Trolley minimum radius (mm)	Net weight (kg)
							50Hz	60Hz	50Hz	60Hz				
DAM-0.25	250kg	313kg	3 or 6	2.5 or 5.5	0.5	0.4	7.8	9.3	20 (MAF) or 10 (MAS)	24 (MAF) or 12 (MAS)	570	75	1100 (800)	73 (77)
DAM-0.5	0.5	625kg			0.9		7.3	8.6			575	100		75 (79)
DAM-1W	1	1.25			0.9		3.6	4.3			740	125		92 (102)
DAM-1S	1	1.25	4	3.5	1.7	0.75	6.8	8.2	20:5	24:6	620	150	1500 (800)	101 (106)
DAM-1.5	1.5	1.88			3.4		8.7	10.3			735	125		192 (200)
DAM-2W	2	2.5			1.7		3.4	4.1			795	100		124 (133)
DAM-2S	2	2.5	4	3.5	3.4	0.75 × 2	6.9	8.1	20:5	24:6	735	125	1500 (1000)	197 (206)
DAM-2.5	2.5	3.13			3.4		5.5	6.5			745	150		192
DAM-3	3	3.75			3.4		4.35	5.15			990	150		209
DAM-5	5	6.25	4	3.5	3.4	0.75 × 0.19 × 2	2.75	3.25	20:5	24:6	1055	125 · 150 · 175	2000 (1000)	246
DAM-7.5	7.5	9.38			3.4		1.8	2.1			1200	150		480
DAM-10	10	12.5			3.4 × 2		2.7	3.2			1180	175		690

- 1) The number bracketed in "Net weight" indicates 6m lift.
 - 2) The length of power cord in standard is 4 core-0.5m in case of 4 push button, 7 core-0.5m in case of 6 push button.
 - 3) When you need 6 push button for crane instead of 4 push button, "C" should be added to the end of model name.
 - 4) We can supply the special electric trolley of which "Trolley mini radius" is the number bracketed off.
- *mark-When you install more than 2.5 ton chain block to 1 beam width 100mm, please note that the strength of the rail may not be enough depends on the span.

DIMENSIONS

MODEL	A	B	C	*γ	D	E	F	G	I	J	K	M
DAM-0.25/DAMB-0.25	482+*2β	251+*β	231+*β	75	168	108	246	120	267	261	125	-
DAM-0.5/DAMB-0.5	482+*2β	251+*β	231+*β	75	168	108	246	120	267	261	125	-
DAM-1W/DAMB-1W	482+*2β	251+*β	231+*β	75	208	68	246	120	267	261	125	-
DAM-1S/DAMB-1S	482+*2β	251+*β	231+*β	75	174	127	246	120	290	274	125	-
DAM-1.5/DAMB-1.5	514+*2β	267+*β	247+*β	100	198	174	324	148	342	313	137	-
DAM-2W/DAMB-2W	514+*2β	267+*β	247+*β	100	219	82	324	148	290	274	137	-
DAM-2S/DAMB-2S	514+*2β	267+*β	247+*β	100	198	174	324	148	342	313	137	-
DAM-2.5/DAMB-2.5	576+*2β	324+*β	252+*β	100	198	174	316	160	342	313	182	-
DAM-3/DAMB-3	576+*2β	324+*β	252+*β	100	258	114	316	160	342	313	182	-
DAM-5/DAMB-5	610+*2β	340+*β	270+*β	125	273	102	336	170	342	313	189	-
DAM-7.5/DAMB-7.5	634+*2β	353+*β	281+*β	150	-	-	696	360	342	313	189	798
DAM-10/DAMB-10	634+*2β	353+*β	281+*β	150	-	-	696	360	342	313	189	990

- 1) The dimensions D,E depends on the lift.
- 2) For the dimensions β and γ, see page 16.
- 3) The dimension K is in case of that "Traversing I beam width" is maximum.

ELECTRIC CHAIN BLOCK WITH ELECTRIC TROLLEY

4 push button type (DB)
For monorail



6 push button type (DB)
For crane



Option: Wiring box for saddle
 • Magnetic contactor and transformer are included.
 • Operating voltage is 24V
 • Power cord and operating cord are not included

4 push button type (DB)
For monorail



6 push button type (DB)
For crane



Option: Wiring box for saddle
 • Magnetic contactor and transformer are included.
 • Operating voltage is 24V
 • Power cord and operating cord are not included

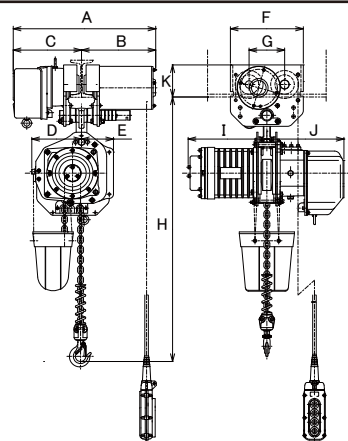

250kg ~ 2.5ton
The drawing of electric trolley 2.5t is different from above drawing.

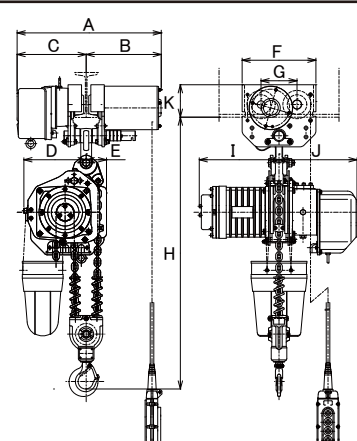

1t ~ 5ton
The drawing of electric trolley 3t, 5t is different from above drawing.

DBM type/DBMB type SPECIFICATION

Model	Capacity (ton)	Test Load (ton)	Standard lift (m)	Standard push button cord length (m)	Lifting motor output (kW) High:Low speed	Traversing motor output (kW)	Lifting speed High:Low speed (m/min)		Traversing speed (M) High:Low (m/min)		Minimum distance H (mm)	Traversing I beam width	Trolley minimum radius (mm)	Net weight (kg)					
							50Hz	60Hz	50Hz	60Hz									
DBM-0.25	250kg	313kg	3 or 6	2.5 or 5.5	0.5:0.17	0.4	7.8:2.6	9.3:3.1	20 (MAF) or 10 (MAS)	24 (MAF) or 12 (MAS)	570	75	1100 (800)	87 (91)					
DBM-0.5	0.5	625kg			0.9:0.3		7.3:2.4	8.6:2.8			575	100		91 (96)					
DBM-1W	1	1.25			0.9:0.3		3.6:1.2	4.3:1.4			740	125		111 (119)					
DBM-1S	1	1.25			1.7:0.57		6.8:2.2	8.2:2.7			620	150		121 (126)					
DBM-1.5	1.5	1.88			3.4:1.14		8.7:2.9	10.3:3.4			735	☆ 100		1500 (800)	213 (220)				
DBM-2W	2	2.5			1.7:0.57		3.4:1.1	4.1:1.3			795	125		144 (153)					
DBM-2S	2	2.5	3.4:1.14	6.9:2.3	8.1:2.7	735	125	217 (227)											
DBM-2.5	2.5	3.13	4	3.5	3.4:1.14	0.75	5.5:1.8	6.5:2.1	20:5	24:6	745	150	1500 (1000)	209					
DBM-3	3	3.75			3.4:1.14		4.35:1.4	5.15:1.7			990	150	226						
DBM-5	5	6.25			3.4:1.14		2.75:0.9	3.25:1.0			1055	125 · 150 · 175	2000 (1000)	263					
DBMB-0.25	250kg	313kg			3 or 6		2.5 or 5.5	0.5:0.17			0.4:0.1	7.8:2.6	9.3:3.1	20:5	24:6	570	75	1100 (800)	87 (91)
DBMB-0.5	0.5	625kg						0.9:0.3				7.3:2.4	8.6:2.8			575	100		91 (96)
DBMB-1W	1	1.25	0.9:0.3	3.6:1.2		4.3:1.4		740	125	111 (119)									
DBMB-1S	1	1.25	1.7:0.57	6.8:2.2		8.2:2.7		620	150	121 (126)									
DBMB-1.5	1.5	1.88	3.4:1.14	8.7:2.9		10.3:3.4		735	☆ 100	1500 (800)		213 (220)							
DBMB-2W	2	2.5	1.7:0.57	3.4:1.1		4.1:1.3		795	125	144 (153)									
DBMB-2S	2	2.5	3.4:1.14	6.9:2.3	8.1:2.7	735	125	217 (227)											
DBMB-2.5	2.5	3.13	4	3.5	3.4:1.14	0.75:0.19	5.5:1.8	6.5:2.1	20:5	24:6	745	150	1500 (1000)	209					
DBMB-3	3	3.75			3.4:1.14		4.35:1.4	5.15:1.7			990	150	226						
DBMB-5	5	6.25			3.4:1.14		2.75:0.9	3.25:1.0			1055	125 · 150 · 175	2000 (1000)	263					

- The number bracketed in "Net weight" indicates 6m lift.
 - The length of power cord in standard is 4 core-0.5m in case of 4 push button, 7 core-0.5m in case of 6 push button.
 - When you need 6 push button for crane instead of 4 push button, "C" should be added to the end of model name.
 - We can supply the special electric trolley of which "Trolley mini radius" is the number bracketed off.
- *mark-When you install more than 2.5 ton chain block to 1 beam width 100mm, please note that the strength of the rail may not be enough depends on the span.

DIMENSIONS

MODEL	A	B	C	*γ	D	E	F	G	I	J	K	M
DBM-0.25/DBMB-0.25	482+*2β	251+*β	231+*β	75	168	108	246	120	276	287	125	-
DBM-0.5/DBMB-0.5	482+*2β	251+*β	231+*β	75	168	108	246	120	303	287	125	-
DBM-1W/DBMB-1W	482+*2β	251+*β	231+*β	75	208	68	246	120	303	287	125	-
DBM-1S/DBMB-1S	482+*2β	251+*β	231+*β	75	174	127	246	120	321	298	125	-
DBM-1.5/DBMB-1.5	514+*2β	267+*β	247+*β	100	198	174	324	148	372	345	137	-
DBM-2W/DBMB-2W	514+*2β	267+*β	247+*β	100	219	82	324	148	321	298	137	-
DBM-2S/DBMB-2S	514+*2β	267+*β	247+*β	100	198	174	324	148	372	345	137	-
DBM-2.5/DBMB-2.5	576+*2β	324+*β	252+*β	100	198	174	316	160	372	345	182	-
DBM-3/DBMB-3	576+*2β	324+*β	252+*β	100	258	114	316	160	372	345	182	-
DBM-5/DBMB-5	610+*2β	340+*β	270+*β	125	273	102	336	170	372	345	189	-

- The dimensions D,E depends on the lift.
- For the dimensions β and γ, see page 16.
- The dimension K is in case of that "Traversing I beam width" is maximum.

ELECTRIC CHAIN BLOCK WITH GEARED TROLLEY

2 push button type (DA·DB)
For monorail

2 push button type (DA·DB)
For monorail

4 push button type (DA·DB)
For crane

4 push button type (DA·DB)
For crane

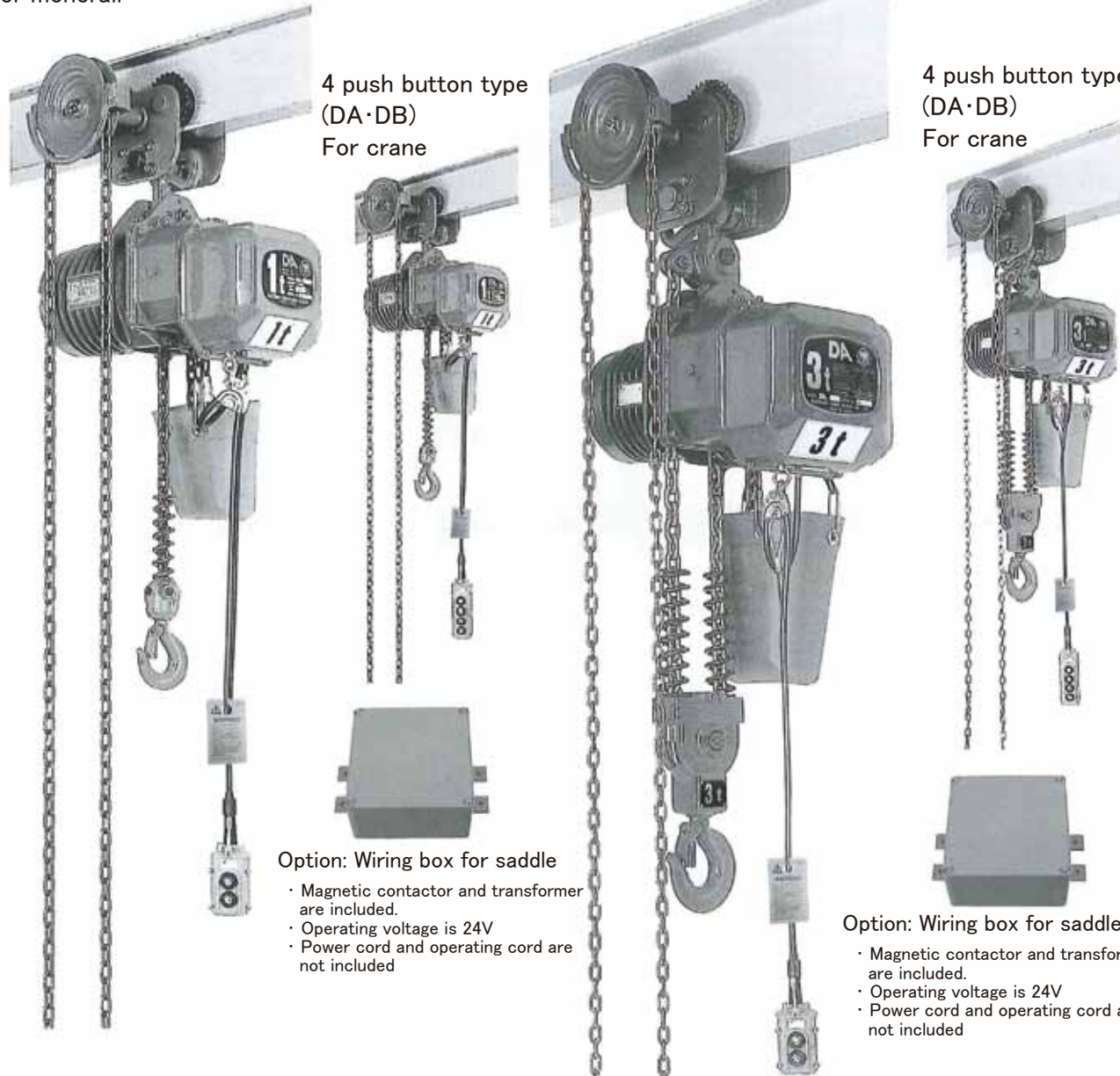

Option: Wiring box for saddle

- Magnetic contactor and transformer are included.
- Operating voltage is 24V
- Power cord and operating cord are not included

Option: Wiring box for saddle

- Magnetic contactor and transformer are included.
- Operating voltage is 24V
- Power cord and operating cord are not included

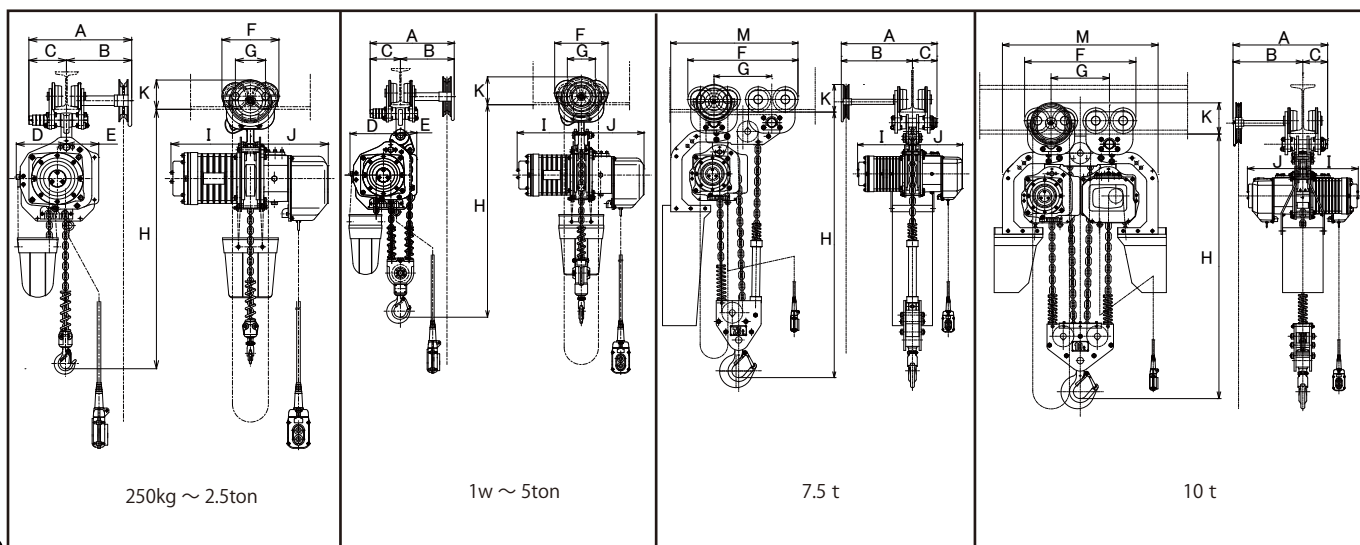

DAG type/DBG type SPECIFICATION

Model	Capacity (ton)	Test Load (ton)	Standard lift (m)	Standard push button cord length (m)	Lifting motor output (kW)	Lifting speed (m/min)		Trolley Traverse distance on 1m hand chain (mm)	Hand chain effort [approx.] kg(N)	Minimum distance H (mm)	Traversing I beam width (mm)	Trolley minimum radius (mm)	Net weight (kg)		
						(DB) High	(DB) Low								
DAG-0.25	250kg	313kg	3 or 6	2.5 or 5.5	0.5	7.8	9.3	139	1 (9.8)	545	75 • 100 • 125	900	64 (69)		
DAG-0.5	0.5	625kg			0.9	7.3	8.6	139	2 (19.6)	550		900	68 (75)		
DAG-1W	1	1.25			0.9	3.6	4.3	114	3.5 (34.3)	715		1100	81 (91)		
DAG-1S	1	1.25			4	3.5	1.7	6.8	8.2	114	3.5 (34.3)	595	★ 100 • 125	1100	89 (97)
DAG-1.5	1.5	1.88					3.4	8.7	10.3	93	4 (39.2)	725		1200	145 (156)
DAG-2W	2	2.5					1.7	3.4	4.1	93	5.5 (54.0)	785		1200	109 (120)
DAG-2S	2	2.5					3.4	6.9	8.1	93	5.5 (54.0)	725	1200	149 (162)	
DAG-2.5	2.5	3.13					3.4	5.5	6.5	97	7 (68.6)	735	1700	161	
DAG-3	3	3.75					3.4	4.35	5.15	97	8 (78.4)	985	1700	178	
DAG-5	5	6.25					3.4	2.75	3.25	84	11.5 (112.7)	1050	125 · 150 · 175	2300	214
DAG-7.5	7.5	9.38	3.4	1.8			2.1	66	15 (147.0)	1190	150 • 175	∞	374		
DAG-10	10	12.5	3.4 × 2	2.7			3.2	66	19 (186.2)	1170	175	∞	513		
DBG-0.25	250kg	313kg	3 or 6	2.5 or 5.5			0.5:0.17	7.8:2.6	9.3:3.1	139	1 (9.8)	545	75 • 100 • 125	900	69 (75)
DBG-0.5	0.5	625kg			0.9:0.3	7.3:2.4	8.6:2.8	139	2 (19.6)	550	900	75 (81)			
DBG-1W	1	1.25			0.9:0.3	3.6:1.2	4.3:1.4	114	3.5 (34.3)	715	1100	87 (97)			
DBG-1S	1	1.25			1.7:0.57	6.8:2.2	8.2:2.7	114	3.5 (34.3)	595	1100	96 (105)			
DBG-1.5	1.5	1.88			3.4:1.14	8.7:2.9	10.3:3.4	93	4 (39.2)	725	1200	162 (173)			
DBG-2W	2	2.5			1.7:0.57	3.4:1.1	4.1:1.3	93	5.5 (54.0)	785	1200	116 (128)			
DBG-2S	2	2.5			3.4:1.14	6.9:2.3	8.1:2.7	93	5.5 (54.0)	725	1200	166 (179)			
DBG-2.5	2.5	3.13			3.4:1.14	5.5:1.8	6.5:2.1	97	7 (68.6)	735	1700	177			
DBG-3	3	3.75			3.4:1.14	4.35:1.4	5.15:1.7	97	8 (78.4)	985	1700	194			
DBG-5	5	6.25			3.4:1.14	2.75:0.9	3.25:1.0	84	11.5 (112.7)	1050	125 · 150 · 175	2300	231		

1) The number bracketed in "Net weight" indicates 6m lift.
 2) The length of power cord in standard is 4 core-5m in case of 2 push button, 7 core-5m in case of 4 push button.
 3) When you need 4 push button for crane instead of 2 push button, "C" should be added to the end of model name.
 4) We can supply geared trolley of which I beam width is special.
 *mark—When you install more than 2.5 ton chain block to I beam width 100mm, please note that the strength of the rail may not be enough depends on the span.

DIMENSIONS

MODEL	A	B	C	*γ	D	E	F	G	I	J	K	M
DAG-0.25/DBG-0.25	345	219+*β	126-*β	75	168	108	190.4	100.4	267/276	261/287	103	-
DAG-0.5/DBG-0.5	345	219+*β	126-*β	75	168	108	190.4	100.4	267/303	261/287	103	-
DAG-1W/DBG-1W	350	224+*β	126-*β	75	208	68	221	116	267/303	261/287	121	-
DAG-1S/DBG-1S	350	224+*β	126-*β	75	174	127	221	116	290/321	274/298	121	-
DAG-1.5/DBG-1.5	381	237+*β	144-*β	100	198	174	259	136	342/372	313/345	160	-
DAG-2W/DBG-2W	381	237+*β	144-*β	100	219	82	259	136	290/321	274/298	160	-
DAG-2S/DBG-2S	462+*2β	237+*β	225+*β	100	198	174	259	136	342/372	313/345	160	-
DAG-2.5/DBG-2.5	464+*2β	237+*β	227+*β	100	198	174	288	150	342/372	313/345	164.5	-
DAG-3/DBG-3	464+*2β	237+*β	227+*β	100	258	114	288	150	342/372	313/345	164.5	-
DAG-5/DBG-5	503+*2β	255+*β	248+*β	125	273	102	327	169	342/372	313/345	180	-
DAG-7.5-DAG-10	597/584	443.5/430.5+*β	153.5-*β	150	-	-	687	360	342	313/342	179	793/960

1) The dimensions D,E depends on the lift. 2) For the dimensions β and γ, see page 16.
 3) The dimension K is in case of that "Traversing I beam width" is maximum.

ELECTRIC CHAIN BLOCK WITH PLAIN TROLLEY

2 push button type (DA·DB)
For monorail



4 push button type (DA·DB)
For crane



Option: Wiring box for saddle

- Magnetic contactor and transformer are included.
- Operating voltage is 24V
- Power cord and operating cord are not included

2 push button type (DA·DB)
For monorail



4 push button type (DA·DB)
For crane



Option: Wiring box for saddle

- Magnetic contactor and transformer are included.
- Operating voltage is 24V
- Power cord and operating cord are not included

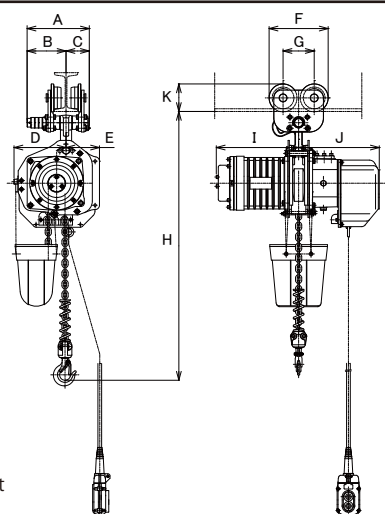

250kg ~ 2.5t

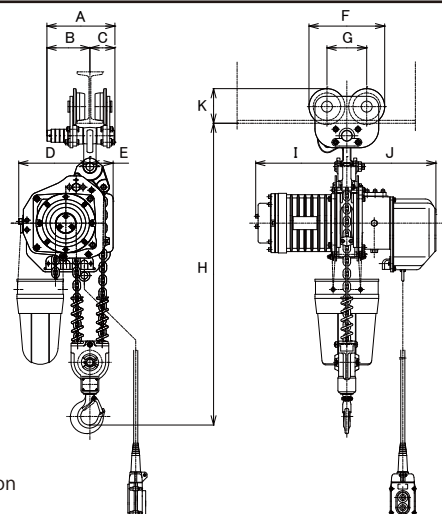

1W ~ 5ton

DAP type/DBP type SPECIFICATION

Model	Capacity (ton)	Test Load (ton)	Standard lift (m)	Standard push button cord length (m)	Lifting motor output (kW) (DB) High:Low speed	Lifting speed (m/min) (DB) High:Low speed		Minimum distance H (mm)	Traversing I beam width (mm)	Trolley minimum radius (mm)	Net weight (kg)
						50Hz	60Hz				
DAP-0.25	250kg	313kg	3 or 6	2.5 or 5.5	0.5	7.8	9.3	545	75	900	58 (61)
DAP-0.5	0.5	625kg			0.9	7.3	8.6	550	100	900	63 (67)
DAP-1W	1	1.25			0.9	3.6	4.3	715	125	1100	73 (79)
DAP-1S	1	1.25			1.7	6.8	8.2	595	☆	1200	137 (144)
DAP-1.5	1.5	1.88			3.4	8.7	10.3	725	100	1200	100 (108)
DAP-2W	2	2.5			1.7	3.4	4.1	785	125	1200	140 (149)
DAP-2S	2	2.5	3.4	6.9	8.1	725	150	1700	152		
DAP-2.5	2.5	3.13	4	3.5	3.4	5.5	6.5	735	125	1700	169
DAP-3	3	3.75			3.4	4.35	5.15	985	150	1700	169
DAP-5	5	6.25			3.4	2.75	3.25	1050	125 · 150 · 175	2300	205
DBP-0.25	250kg	313kg	3 or 6	2.5 or 5.5	0.5:0.17	7.8:2.6	9.3:3.1	545	75	900	64 (67)
DBP-0.5	0.5	625kg			0.9:0.3	7.3:2.4	8.6:2.8	550	100	900	69 (73)
DBP-1W	1	1.25			0.9:0.3	3.6:1.2	4.3:1.4	715	125	1100	79 (86)
DBP-1S	1	1.25			1.7:0.57	6.8:2.2	8.2:2.7	595	☆	1200	153 (160)
DBP-1.5	1.5	1.88			3.4:1.14	8.7:2.9	10.3:3.4	725	100	1200	108 (116)
DBP-2W	2	2.5			1.7:0.57	3.4:1.1	4.1:1.3	785	125	1200	157 (167)
DBP-2S	2	2.5	3.4:1.14	6.9:2.3	8.1:2.7	725	150	1700	168		
DBP-2.5	2.5	3.13	4	3.5	3.4:1.14	5.5:1.8	6.5:2.1	735	125	1700	185
DBP-3	3	3.75			3.4:1.14	4.35:1.4	5.15:1.7	985	150	1700	185
DBP-5	5	6.25			3.4:1.14	2.75:0.9	3.25:1.0	1050	125 · 150 · 175	2300	221

1) The number bracketed in "Net weight" indicates 6m lift.
 2) The length of power cord in standard is 4 core-5m in case of 2 push button, 7 core-5m in case of 4 push button.
 3) When you need 4 push button for crane instead of 2 push button, "C" should be added to the end of model name.
 4) We can supply plain trolley of which I beam width is special.
 *mark—When you install more than 2.5 ton chain block to I beam width 100mm, please note that the strength of the rail may not be enough depends on the span.

DIMENSIONS

MODEL	A	B	C	*γ	D	E	F	G	I	J	K
DAP-0.25/DBP-0.25	202	76+*β	126-*β	75	168	108	190.4	100.4	267/276	261/287	94
DAP-0.5/DBP-0.5	202	76+*β	126-*β	75	168	108	190.4	100.4	267/303	261/287	94
DAP-1W/DBP-1W	200	74+*β	126-*β	75	208	68	221	116	267/303	261/287	106.5
DAP-1S/DBP-1S	200	74+*β	126-*β	75	174	127	221	116	290/321	274/298	106.5
DAP-1.5/DBP-1.5	238	94+*β	144-*β	100	198	174	259	136	342/372	313/345	135
DAP-2W/DBP-2W	238	94+*β	144-*β	100	219	82	259	136	290/321	274/298	135
DAP-2S/DBP-2S	319+*2β	94+*β	225+*β	100	198	174	259	136	342/372	313/345	135
DAP-2.5/DBP-2.5	325+*2β	98+*β	227+*β	100	198	174	288	150	342/372	313/345	150.5
DAP-3/DBP-3	325+*2β	98+*β	227+*β	100	258	114	288	150	342/372	313/345	150.5
DAP-5/DBP-5	372+*2β	124+*β	248+*β	125	273	102	327	169	342/372	313/345	167.4

1) The dimensions D,E depends on the lift. 2) For the dimensions β and γ, see page 16.
 3) The dimension K is in case of that "Traversing I beam width" is maximum.

LOW HEAD ELECTRIC CHAIN HOIST

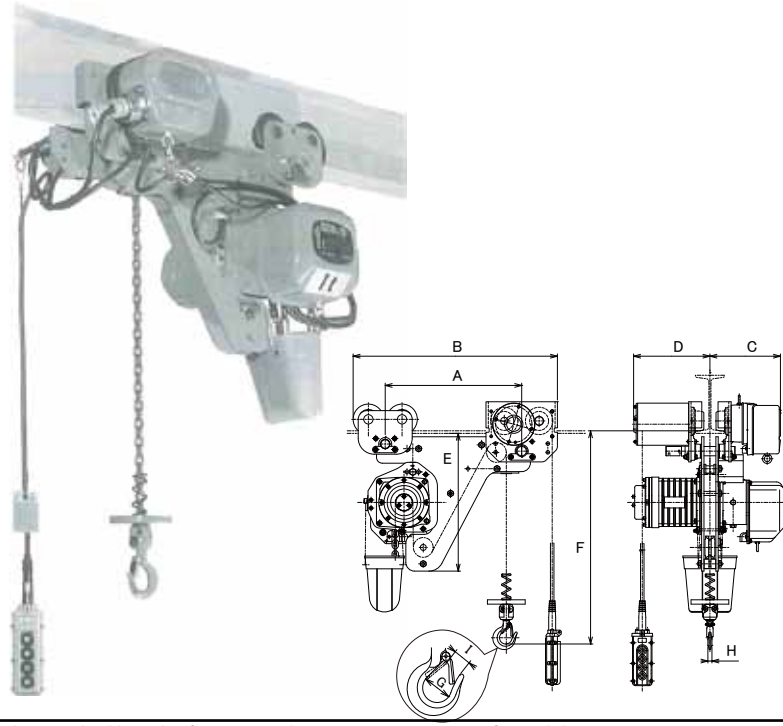

Model	Capacity (ton)	Test load (ton)	Standard lift (m)	Push button length (m)	Load chain Diameter × Number of falls	Lifting motor output (kW) (SDBM) High:Low	Traversing motor output (kW)	Lifting speed(m/min)		Traversing speed(m/min)		Headroom H(mm)	I beam width (mm)	Dimensions (mm)														
								50Hz High : Low	60Hz High : Low	High speed (Standard) (50/60 Hz)	Low speed (50/60 Hz)			A	B	C	D	E	F	G	H	I						
SDAM-0.25	250kg	313kg	3 or 6	2.5 or 5.5	6.3×1	0.9	0.4	7.3	8.6	20/24 or 20:5/24:6	10/12	388	100·125	470	704	261	267	483	388	43	14	26						
SDAM-0.5	0.5	625kg			6.3×1	0.5		4.8	5.7			388		470	704	261	303	483	388	43	14	26						
SDAM-1W	1	1.25			6.3×2	0.9		3.6	4.3			474		470	704	261	267	483	474	50	15	31						
SDAM-1S	1	1.25			7.1×1	1.1		4.5	5.4			421		500	734	273	320	524	421	50	15	31						
SDAM-1.5	1.5	1.88			9.5×1	3.4		5.6	6.8			511		610	902	312	341	613	511	65	26	38						
SDAM-2W	2	2.5			7.1×2	1.7		3.4	4.1			508		510	802	273	290	538	508	65	26	38						
SDAM-2S	2	2.5	11.2×1	3.4	5.5	6.5	562	630	922	312	341	635	562	65	26	38												
SDAM-2.5	2.5	3.13	4	3.5	11.2×1	2.5	0.75	3.6	4.3	20/24 or 20:5/24:6	10/12	565	125·150	630	932	312	371	639	565	65	26	38						
SDAM-3	3	3.75			9.5×2	3.4		4.35	5.15			640		610	912	312	341	617	640	60	32	44						
SDAM-5	5	6.25			11.2×2	3.4		2.75	3.25			745		670	1002	312	341	675	745	70	35	48						
SDBM-0.25	250kg	313kg			3 or 6	2.5 or 5.5		6.3×1	0.9:0.3			0.4 or 0.4:0.1		7.3:2.4	8.6:2.8	20/24 or 20:5/24:6	10/12	388	100·125	470	704	287	303	483	388	43	14	26
SDBM-0.5	0.5	625kg						6.3×1	0.9:0.3					7.3:2.4	8.6:2.8			388		470	704	287	303	483	388	43	14	26
SDBM-1W	1	1.25	6.3×2	0.9:0.3			3.6:1.2	4.3:1.4	474	470	704		287	303	483			474		50	15	31						
SDBM-1S	1	1.25	7.1×1	1.7:0.57			6.8:2.2	8.2:2.7	421	500	734		297	320	524			421		50	15	31						
SDBM-1.5	1.5	1.88	9.5×1	3.4:1.14			5.6:1.9	6.8:2.3	511	610	902		344	371	613			511		65	26	38						
SDBM-2W	2	2.5	7.1×2	1.7:0.57			3.4:1.1	4.1:1.3	508	510	902		297	320	538			508		65	26	38						
SDBM-2S	2	2.5	11.2×1	3.4:1.14	5.5:1.8	6.5:2.1	562	630	922	344	371	635	562	65	26	38												
SDBM-2.5	2.5	3.13	4	3.5	11.2×1	3.4:1.14	0.75 or 0.75:0.19	5.5:1.8	6.5:2.1	20/24 or 20:5/24:6	10/12	565	125·150	630	932	344	371	639	565	65	26	38						
SDBM-3	3	3.75			9.5×2	3.4:1.14		4.35:1.4	5.15:1.7			640		610	912	344	371	617	640	60	32	44						
SDBM-5	5	6.25			11.2×2	3.4:1.14		2.75:0.9	3.25:1.0			745		670	1002	344	371	675	745	70	35	48						

- 1) The standard length of power cord is 4 core-0.5m in case of 4 push button, 7 core-0.5m in case of 6 push button.
- 2) When you need 6 push button for crane instead of 4 push button, "C" should be added to the end of model name.

SYNCHRONIZED ELECTRIC CHAIN HOIST

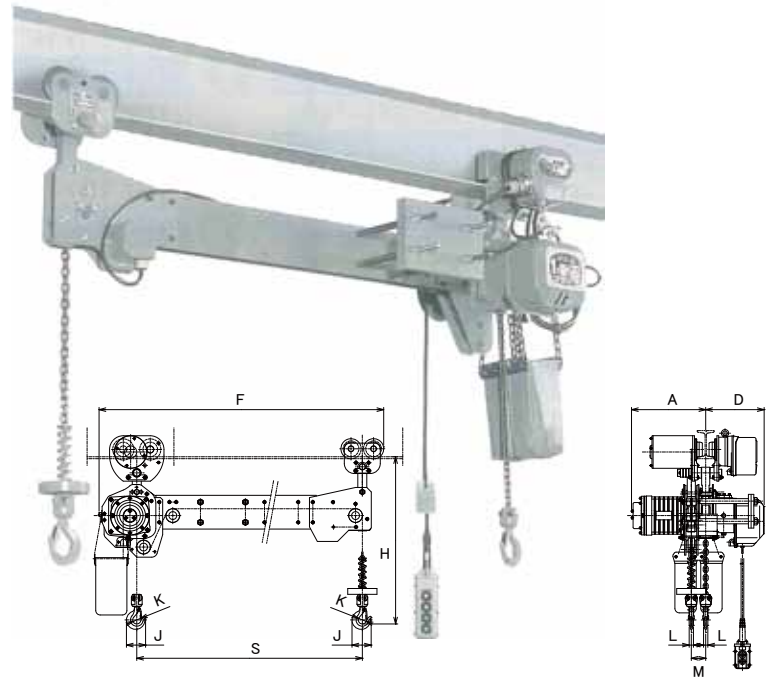

Model	Capacity (ton)	Test load (ton)	Standard lift (m)	Push button length (m)	Load chain Diameter × Number of falls	Lifting motor output (kW) (SDBM) High:Low	Traversing motor output (kW)	Lifting speed(m/min)		Traversing speed(m/min)		Headroom H(mm)	I beam width (mm)	Dimensions (mm)														
								50Hz High : Low	60Hz High : Low	High speed (Standard) (50/60 Hz)	Low speed (50/60 Hz)			A	D	F	G	J	K	L	M							
WDAM-0.25	250kg	313kg	3 or 6	2.5 or 5.5	6.3×1	0.9	0.4 or 0.4:0.1	7.4	8.7	20/24 or 20:5/24:6	10/12	628	75 · 100 · 125	331	261	G+263	※ (600) 1000 4000	84	43	14	64							
WDAM-0.5	0.5	625kg			6.3×1	0.9		7.3	8.6			628		331	261	G+263		84	43	14	64							
WDAM-1W	1	1.25			6.3×2	0.9		3.6	4.3			820		331	261	G+319		103	50	15	64							
WDAM-1S	1	1.25			7.1×1	1.7		6.8	8.2			691		361	274	G+285		103	50	15	71							
WDAM-1.5	1.5	1.88			9.5×1	3.4		8.7	10.3			830		432	313	G+328		135.5	65	26	90							
WDAM-2W	2	2.5			7.1×2	1.7		3.4	4.1			870		361	274	G+349		135.5	65	26	71							
WDAM-2S	2	2.5	11.2×1	3.4	6.9	8.10	838	432	313	G+328	135.5	65	26	90														
WDAM-2.5	2.5	3.13	4	3.5	11.2×1	3.4	0.75 or 0.75:0.19	5.5	6.50	20/24 or 20:5/24:6	10/12	845	100 · 125 · 150	432	313	G+342	※ (600) 1000 4000	135.5	65	26	90							
WDAM-3	3	3.75			9.5×2	3.4		4.35	5.15			1040		432	313	G+402		165	60	32	90							
WDAM-5	5	6.25			11.2×2	3.4		2.75	3.25			1155		432	313	G+437		183	70	35	90							
WDBM-0.25	250kg	313kg			3 or 6	2.5 or 5.5		6.3×1	0.9:0.3			0.4 or 0.4:0.1		7.4:2.5	8.7:2.9	20/24 or 20:5/24:6		10/12	628	75 · 100 · 125	367	287	G+263	※ (600) 1000 4000	84	43	14	64
WDBM-0.5	0.5	625kg						6.3×1	0.9:0.3					7.3:2.4	8.6:2.8				628		367	287	G+263		84	43	14	64
WDBM-1W	1	1.25	6.3×2	0.9:0.3			3.6:1.2	4.3:1.4	820	367	287		G+319	103	50		15		64									
WDBM-1S	1	1.25	7.1×1	1.7:0.57			6.8:2.2	8.2:2.7	691	392	298		G+285	103	50		15		71									
WDBM-1.5	1.5	1.88	9.5×1	3.4:1.14			8.7:2.9	10.3:3.4	830	462	345		G+328	135.5	65		26		90									
WDBM-2W	2	2.5	7.1×2	1.7:0.57			3.4:1.1	4.1:1.3	870	392	298		G+349	135.5	65		26		71									
WDBM-2S	2	2.5	11.2×1	3.4:1.14	6.9:2.3	8.1:2.7	838	462	345	G+328	135.5	65	26	90														
WDBM-2.5	2.5	3.13	4	3.5	11.2×1	3.4:1.14	0.75 or 0.75:0.19	5.5:1.8	6.5:2.1	20/24 or 20:5/24:6	10/12	845	100 · 125 · 150	462	345	G+342	※ (600) 1000 4000	135.5	65	26	90							
WDBM-3	3	3.75			9.5×2	3.4:1.14		4.35:1.4	5.15:1.7			1040		462	345	G+402		165	60	32	90							
WDBM-5	5	6.25			11.2×2	3.4:1.14		2.75:0.9	3.25:1.0			1155		462	345	G+437		183	70	35	90							

- 1) The standard length of power cord is 4 core-0.5m in case of 4 push button, 7 core-0.5m in case of 6 push button.
- 2) When you need 6 push button for crane instead of 4 push button, "C" should be added to the end of model name.

LOW HEAD MANUAL CHAIN HOIST WITH GEARED TROLLEY

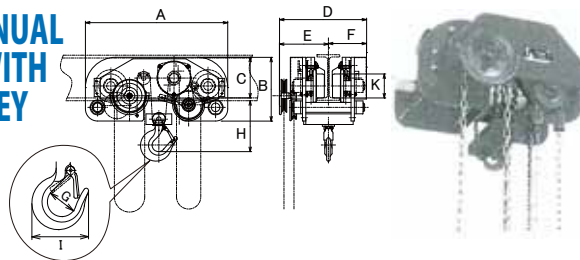

Model	Capacity (ton)	Test load (ton)	Standard lift (m)	Load chain Diameter × Number of falls	Hand effort to lift full working load kg(N)	Hand effort to move geared trolley kg(N)	Headroom H(mm)	I beam width (mm)	A	B	C	D	E	F	G	I	J	K
SHG-0.5	500kg	625kg	2.5	5×4	25(245)	5(49.0)	131	125	555	278	177	498	289	209	30	84	19	80
SHG-1	1	1.25		5×4	28(275)	5(49.0)	155	125	555	278	177	498	289	209	50	103	15	80
SHG-1.6	1.6	2.0		5×4	38(373)	4(39.2)	180	125	555	278	180	498	289	209	65	136	26	98
SHG-2	2	2.5	3	5×4	37(363)	5.5(54.0)	180	125	555	278	180	498	289	209	65	136	26	98
SHG-3.1	3.15	4.0		7.1×4	38(373)	8(78.4)	201	150	697	350	226.5	516	295	221	60	165	35	115
SHG-5	5	6.3		7.1×4	38(373)	11.5(112.7)	225	150	742	405	226.5	546	307	239	70	183	35	125
SHG-10	10	12.5		9×4	40(392)	27(265)	260	150	938	420	268	574	323	251	85	238	50	158
SHG-20	20	25		9×4	50(490)	40(392)	414.5	175	1150	500	333.5	600	340	260	110	315	80	197

Combination of Electric Trolleys with Traversing Rails (Model DAM, DBM)

	Color	I-600X190X16	I-600X190X13	I-450X175X13	I-450X175X11	I-400X150X12.5	I-400X150X10	I-350X150X12	I-350X150X9	I-300X150X11.5	I-300X150X10	I-300X150X8	I-250X125X10	I-250X125X7.5	I-200X150X9	I-200X100X7	I-180X100X6	I-150X125X8.5	I-150X75X5.5	I-125X75X5.5	I-100X75X5	
		Electric Trolley 0.25 · 0.5 · 1S · 1W	(a)					252	266	204	222	158	165	176	113	126	70	81	61	23	31	
	(b)					23	30	24	33	26	29	35	28	35	32	36	36	33	36			
Electric Trolley 1.5 · 2S · 2W	(a)			288	301	240	254	192	210	146	153	164	101	114	58	68						
	(b)			17	23	17	24	18	27	20	24	29	22	29	26	30						
Electric Trolley 2.5 · 3	(a)			302	314	253	267	205	223	159	166	178	115	128	71							
	(b)			13	19	13	20	14	23	16	19	25	18	24	22							
Electric Trolley 5	(a)	428	448	295	308	247		199		153			108									
	(b)	15	25	24	30	24		25		27			29									
Electric Trolley 7.5 · 10	(a)	428	448	295	308	247		199		153												
	(b)	9	19	18	24	18		19		21												

Combination of Plain/Geared Trolleys with Traversing Rails (Model DAG, DBG, DAP, DBP)

	Color	I-600X190X16	I-600X190X13	I-450X175X13	I-450X175X11	I-400X150X12.5	I-400X150X10	I-350X150X12	I-350X150X9	I-300X150X11.5	I-300X150X10	I-300X150X8	I-250X125X10	I-250X125X7.5	I-200X150X9	I-200X100X7	I-180X100X6	I-150X125X8.5	I-150X75X5.5	I-125X75X5.5	I-100X75X5	
		Geared Trolley Plain Trolley 0.25 · 0.5	(a)						296		252		195	207		157	100	111	91	54	61	36
	(b)						5		8		5	10		10	7	12	12	8	11	11		
Geared Trolley Plain Trolley 1S · 1W	(a)						287		243		186	197	134	147	91	102	81	44	51			
	(b)						5		9		5	11	4	10	8	12	12	9	11			
Geared Trolley Plain Trolley 1.5 · 2S · 2W	(a)			303	315	254	268	206	224	160	167	179	116	129	72	83						
	(b)			7	13	7	14	8	17	10	13	19	12	18	16	20						
Geared Trolley Plain Trolley 2.5 · 3	(a)			286	298	237	251	189	207	143	150	161	98	111	55							
	(b)			5	11	5	12	6	15	8	11	17	10	17	14							
Geared Trolley Plain Trolley 5	(a)	428	275	287	226		178		132				88									
	(b)	17	15	21	15		16		18				20									
Geared Trolley Plain Trolley 7.5 · 10	(a)	428	275	287	226		178		132													
	(b)	11	9	15	9		10		12													

- For understanding the descriptions at the upper row of the Table:
 - As for the rails belonging to the blue indicated zone, the standard type trolleys can be fitted to each of them.
 - As for the rails belonging to the gray-indicated zone, such trolleys as having special dimensions to meet them must be prepared separately.
- For understanding the descriptions at the medium row of the Table:
 Each of the figures indicated at this row shows the distance [a](unit:mm) of the sketch at right side. This distance [a] may be zero or negative depending on the combination of the standard trolley with some types of rails: for this case, no figure is given here because such combination can't be put in actual application. In the case of the combination indicated with a blue figure, the trolley's top is higher than the rail's top so that the trolley may touch the ceiling suspending the rail ($H \leq K$): pay attention to this.
- For understanding the descriptions at the lower row of the Table:
 Each of the figures indicated at this row shows the distance [b](unit:mm) of the sketch at the right side. The distance [b] may be zero or negative depending on the combination of the standard trolley with some type of rails: for this case, no figure is given here because such combination can't be put in actual application. Also for the rails whose thickness t_2 is too thin to hold the rated load, no figure is given.

If there is even one blank at either of the upper, medium and lower rows of the Table, this means that such relevant rail can't be used to together with the trolleys.

In this way, referring to the Table, you will see what type of rail(I beam) is suited to the trolley you have selected.

Then it is needed to check if such rail satisfies the following condition: even if it is given a 125% of the rated safety load, its deflection amount shall be 1/1200 of its support span or less. That is, the I beam to be selected shall have its moment of inertia of the longitudinal section (Ix) be as follows:

I_x : Moment of inertia of the longitudinal section $\geq 119.1 \times W \times L^2$
 In which,
 W: W.L.L. $\times 1.25$ + Chain block's own weight(ton)
 L: Support span(m)

※continued from page 15
 For "Combination of Electric Trolleys with Traversing Rails", the following must be taken note of:
 At the medium row of the table:
 In the case of the combination indicated with a gray zone, the relation $H \leq K$ applies to both plain trolley and geared trolley.
 In the case of the combination indicated with a blue zone, the relation $H \leq K$ applies only to the geared trolley.

*The dimensions A, B, C of the trolley will vary with the change of the traversing rail's width to be used.
 The figure β in the Table can be obtained from the following equation: $\beta = 1/2x[\text{width(mm) of the traversing rail} - \gamma]$

NOTES ON THE WIRING DIAGRAM

- Our electric chain blocks(with the trolleys included), either DA type or DB type, are usually designed to operate on the 3-phase power source.
 The electrical parts used for our chain blocks are all the precision ones which can normally operate even with an accidental voltage drop (with a 10% reduction of the rated voltage)
- As standard, our lifting motor (LM) and trolley motor (TM) are respectively assured of the following ratings.

	Insulation class	Short time duty	Intermittent duty
LM	E	30 minutes	40% ED, Number of starts : 240/h
TM	E	15 minutes	25% ED, Number of starts : 240/h

In the case of the DB type, however, its rating will be like:

Short time duty		Intermittent duty	
High speed	Low speed	High speed	Low speed
30 minutes	15 minutes	40% ED, Number of starts : 240/h	20% ED, Number of starts : 120/h
- As to the 4-core power cord, or the 7-core cabtyre cord used for the DAGC, DBGC, DAPC or DBPC type, they are each usually of 5m in length. The cords of other length than the above, or of special dimensions, are available upon request.
- When connecting the power cord to the power source, take care of its correct phase so that the lifting motor can rotate in UP direction and DN direction according to the push of the UP button and DN button on the control switch. If the connection phase is reversed, the negative phase protector starts to work to prevent the lifting motor from rotating in either direction. If this occurs, exchange the connection phase of the black and red leads from each other: at the time, avoid changing the wire connections in the control switch, chain block and trolley.
- The running direction of the electric trolley and/or the saddle has been decided at the shipment, and it may be changed, at your site, by changing the wire connection at the control switch case.

HOIST CLASSIFICATION

	JIS/ISO classification	FEM classification	ASME classification	International protection
DA	M5	2m	H3	IP54
DB	M5	2m	H3	IP54

LARGE CAPACITY CHAIN BLOCK

Electric chain block

Model No.	Capacity(ton)	Standard lift(m)	Lifting speed(m/min)		Lifting motor output(kW)	Min. hook-to hook distance(mm)	No. of load chain fall
			50Hz	60Hz			
DA-15	15	4	1.8	2.1	3.4×2	1390	11.2×6
DA-20	20	4	1.3	1.6	3.4×2	1680	11.2×8
DA-30	30	4	0.8	1.0	3.4×2	1710	11.2×12
DA-50	50	4	0.5	0.6	3.4×2	2900	11.2×22
DA-60	60	4	0.4	0.5	3.4×2	2900	11.2×26

Electric chain block with electric trolley

Model No.	Capacity(ton)	Standard lift(m)	Traversing speed(m/min)		Traversing motor output(kW)	Trolley min radius(mm)	No. of load chain fall
			50Hz	60Hz			
DAM-15	15	4	10	12	1.5	∞	11.2×6
DAM-20	20	4	10	12	1.5	∞	11.2×8

Electric chain block with geared trolley

Model No.	Capacity(ton)	Standard lift(m)			Trolley min radius(mm)	No. of load chain fall
DAG-15	15	4	-	-	7000	11.2×6
DAG-20	20	4	-	-	7000	11.2×8

HOOK DIMENSIONS · BOTTOM HOOK WEIGHT · LOAD CHAIN WEIGHT

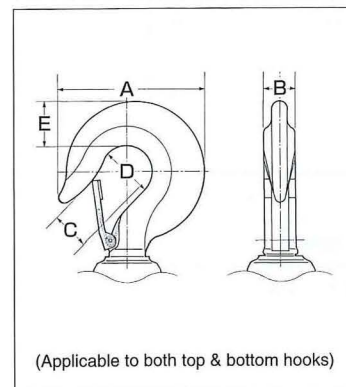

Max working load & number of falls	0.25	0.49	0.5	1S	1W	1.5	2S	2W	2.5	3	5	7.5	10	DIMENSION (mm)											
														A	B	C	D	E							
															74	84	103	136	136	136	165	170	243	230	
															15	14	19	26	26	26	32	35	48	48	
															26	26	30	40	40	40	44	47	73	73	
															35	43	50	65	65	65	60	70	85	85	
															18	19	25	35	35	35	49	53	63	63	
Bottom hook weight(kg)	0.8	0.83	1.4	3.7	2.8	3.5	5.8	3.55	11.1	16.7	65	80													
No. of fall load chain	1	1	1	2	1	1	2	1	2	2	3	4													
Load chain weight(kg)	Per meter	0.68	0.86	1.10	0.86	1.96	2.66	1.10	2.66	1.96	2.66	2.66	2.66												
		Per lift meter				1.72	1.96	2.66	2.20	3.92	5.33	8.00	10.67												

● A hook is produced by the process of hot forging, and so its dimensions may have some errors : ±2% for 0.25~5t hook and ±3% for the 7.5 and/or 10t hook.

Reading of Model/Code

DA-0.25
DBP-3
DAG-2 S
DAMC-1 W

Typical Examples

- To show the number of falls
- To show the rated load capacity(ton)
- To show the class of each model

- Class code:
It identifies the type (single speed or dual speed type), the number of buttons on the control switches and kinds of trolleys (electric, geared or plain). See the sketches at right.
- Rated load capacity:
It shows the rated load capacity(ton) of the relevant chain block.
- Number of falls:
It identifies whether the relevant chain block is the 1-fall type or the 2-fall type block(S=1, W=2).

Note: Indication of the number of falls is omitted for certain model in the case where it has been specified according to its rated load capacity.

Class Code

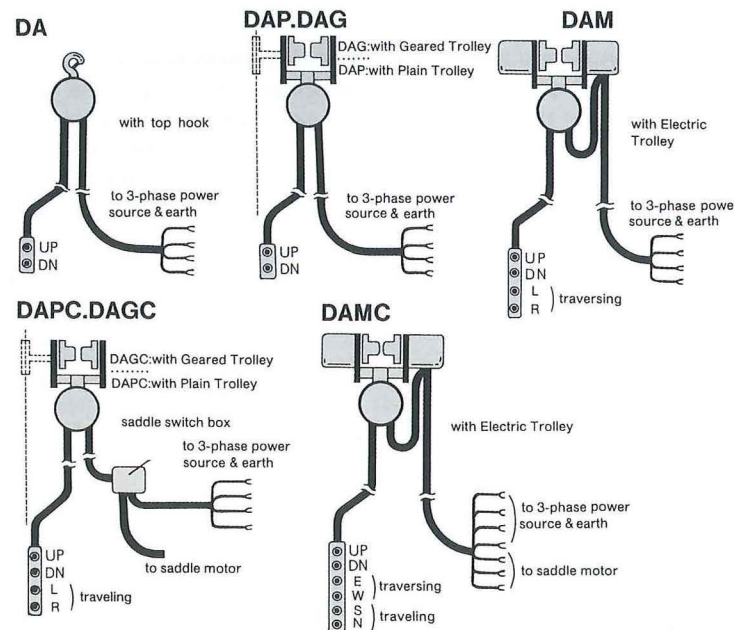

- Usually the pushbuttons located on the control switch are labeled as "UP", "DN", "L", "R", "E", "W", "S" and "N". The other types of labeling are available upon request.
- In the case of the dual speed type (DB type), the chain block can be wound UP and DOWN at either high speed or low speed. The UP ↑ and Down ↓ buttons are each of push-push type: at the first push, it provided low speed operation and at the second push, it provides high speed operation.

DEFINITION OF WORDS

Lift and Length of Pushbutton Switch Cord

As the electric chain block is operated, its bottom hook moves up and down and the longest distance of this motion is called a "lift". In other words, the lift refers to the distance between the bottom hook's highest position (with the upper limit switch actuated) and its lowest position (with the lower limit switch actuated). The length of the pushbutton switch cord refers to the distance between the bottom of dimension L and the lower surface of the pushbutton switch case.

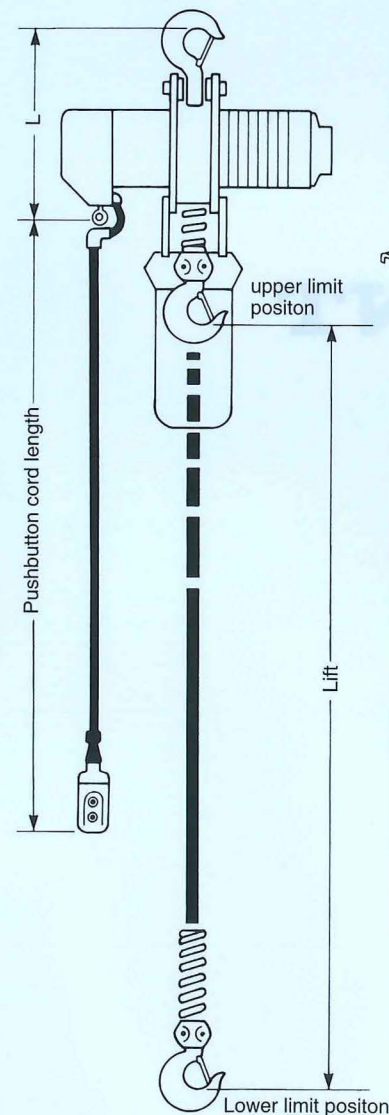

Traversing, Traveling with Trolley and Saddle.

The electric chain block, while hoisting any of loads, may be moved in lateral or longitudinal direction when used in combination with a trolley or saddles which is fitted on a rail. Usually, the trolley is used for a lateral motion of the electric chain block and saddles for a longitudinal motion of it. And when the chain block moves laterally, we call it as "traversing" and when it moves longitudinally, we call it "traveling". Depending on your job requirements, the ELEPHANT electric chain blocks may be combined with different types of saddles of our own; refer to our catalog "ELEPHANT Electric Saddles".

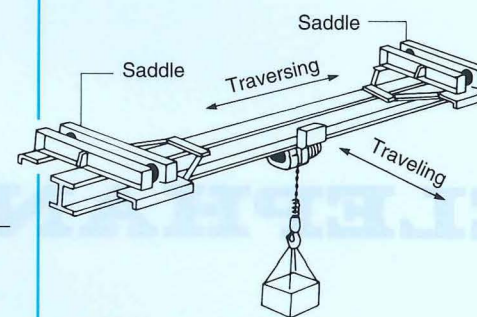

Short Time Duty Rating and Intermittent Duty Rating

As a criterion to indicate the strength and durability of our electric chain blocks. We have specified the ratings of the short time duty and intermittent duty concerning their included electric motors—see the page 12 of catalogs.

● **Short Time Duty Rating**
"Short time duty rating" means the limited time that the admissible temperature limit of its electric motor won't be exceeded, when the electric chain block is operated continuously on the below cycle.

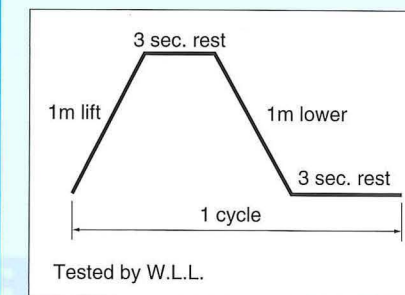

● **Intermittent Duty Rating**
Compared with "short time duty rating", the temperature of motor rises gradually by properly giving rests to the chain block between its operating periods (lifting and lowering). The percentage duty cycle ED is found as follows.

$$\%ED = \frac{\text{Operating periods}(t_1+t_2)}{\text{Operating} + \text{Rest periods}(T)} \times 100$$

based on the maximum cycle period of 10 minutes. The number of starts/h also affects the rise of temperature. Thus these two factors are specified to show the intermittent duty rating of the electric chain block under the specification of which the electric motor can be operated safely without exceeding its admissible temperature limit.

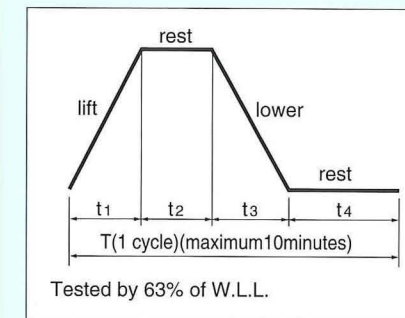

ELEPHANT



ELEPHANT CHAIN BLOCK CO.,LTD.

180,Iwamuro 2-chome, Osaka-sayama city, Osaka, Japan

E-mail: elp_trade@elephant.co.jp

URL <http://www.elephant.co.jp/english/index.html>

